

# IM R SERIES

TRACK DRIVEN CRAWLER ACCESS PLATFORMS | INDOOR / OUTDOOR



## IM R 23 DA

### PERFORMANCE

Working Height 68'  
Platform Height 75'

75'  
working height

### STANDARD EQUIPMENT

- Automatic outrigger leveling system
- 355° rotation (non-continuous)
- 120V, 16 amp electric motor for indoor use
- Air / Water outlet in the platform basket
- 120V - 16A AC power to platform
- Removable wireless control box
- Tether for wired connectivity
- Max 510 lbs max in basket (two person capacity)
- Three travel speeds
- Emergency hand pump
- Cylinder holding valves
- Hour meter
- Load and tip detection sensor
- Load cell
- Hydraulic jib
- Rubber tracks
- Remote battery charger
- Removable basket with 1 pin detach
- Overload sensor
- 120V battery charger
- Honda iGX800 Gas Engine
- Hydraulically adjustable track width
- Hydraulic basket rotation - 124°

### OPTIONAL EQUIPMENT

- Non-marking rubber tracks
- Working light in the platform basket
- 12 V emergency pump
- Yanmar 3TNV70 Diesel Engine
- IMERVIEW GPS Remote Monitor System

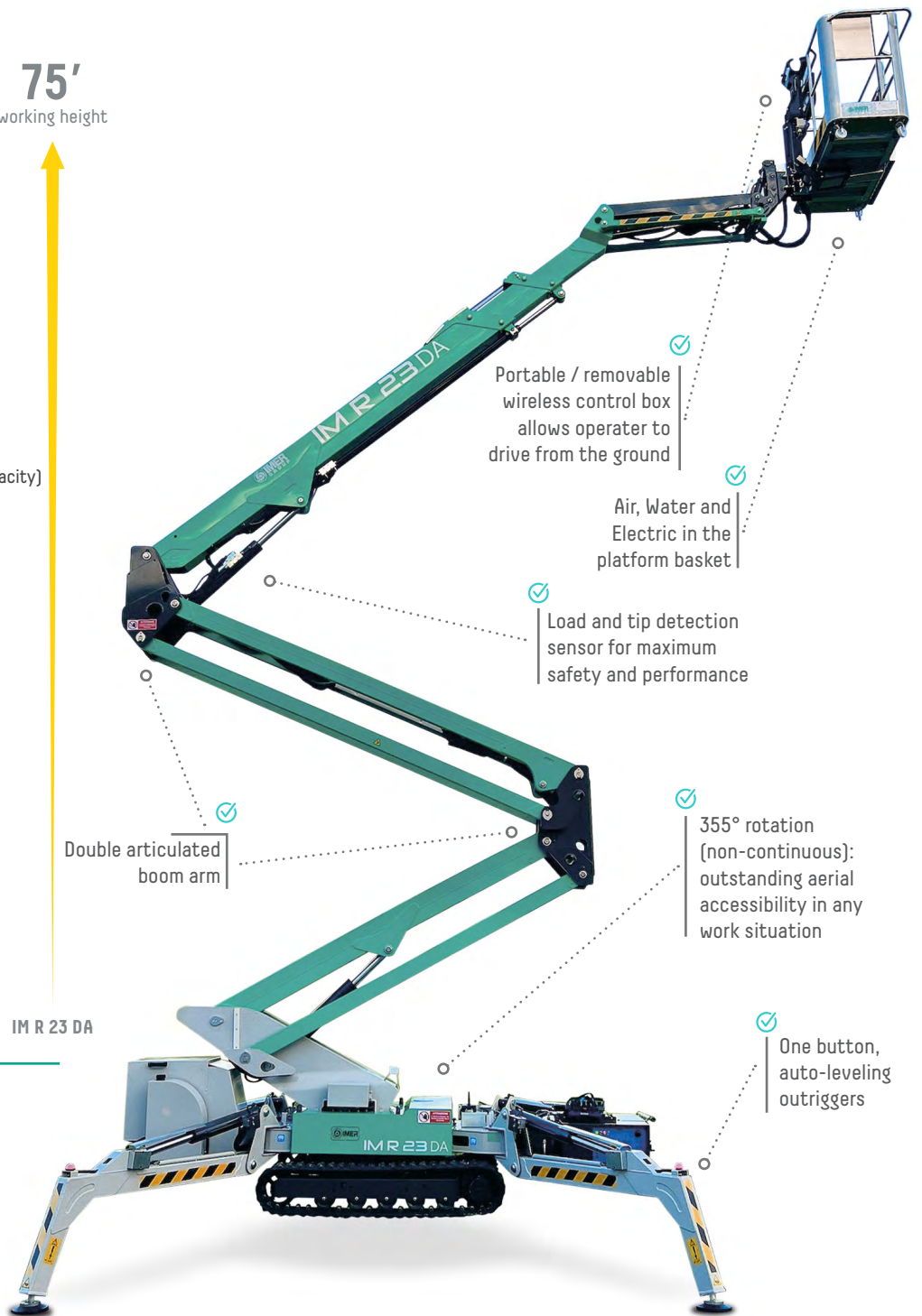

Portable / removable wireless control box allows operator to drive from the ground

Air, Water and Electric in the platform basket

Load and tip detection sensor for maximum safety and performance

Double articulated boom arm

355° rotation (non-continuous): outstanding aerial accessibility in any work situation

One button, auto-leveling outriggers



# IM R SERIES

TRACK DRIVEN CRAWLER ACCESS PLATFORMS | INDOOR / OUTDOOR



This machine meets or exceeds applicable ANSI and CSA requirements based on machine configuration as originally manufactured for intended applications. Reference the serial number plate on the machine for additional information.



**FAST & SECURE LEVELING**  
Automatic outrigger leveling system for quick set up and peace of mind.



**EASY USER EXPERIENCE**  
A user-friendly control panel, easily removable wireless remote control allows for more space in the basket and navigation from the ground.



**EASY ACCESS**  
In addition to the removeable control box in the basket, the IM R Series includes an easy to access ground control panel.

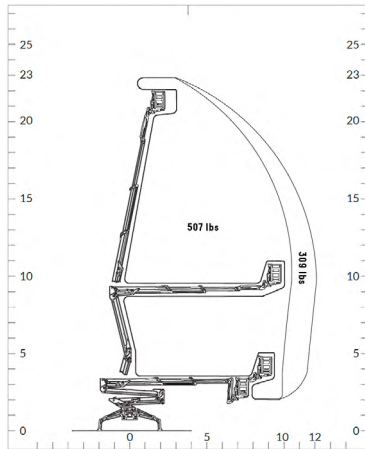

**ADJUSTABLE TRACKS**  
Hydraulically adjust the track width for added stability and traction, and to fit through narrow doorways and gates for interior or exterior projects

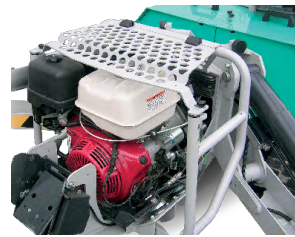

**BI-ENERGY POWER**  
A Honda Engine and Electric Motor provide a bi-energy solution, allowing both indoor and outdoor use (shown with a rugged engine guard for improved protection)



**SUPERIOR ROTATION**  
Outstanding accessibility with a 355° rotation (non-continuous) and 124° jib rotation

		IM R 23 DA
Working height	ft	75'
Platform height	ft	68'
Side outreach (weight in basket)	ft / lb	35' / 507 - 39' / 308
Rotation (non-continuous)	deg	355°
Basket dimensions	in	54" x 30" x 42"
Basket rotation	deg	124°
Transport length (without basket)	ft	18' 8" (4' 2")
Transport width (with expanded tracks)	ft	3' 2" (4' 2")
Height in stowed position	ft	6' 6"
Overall outrigger footprint	ft	12' 9" x 12' 1"
Stabilizer load	ft-lb	3930
Driving speed	mph	0 - 1.7 mph
Gradeability	%	18%
Platform capacity	lb	510
Gas motor		Honda iGX800
Machine weight	lb	Gas - 6,525 lbs / Diesel - 6,613

