



S/N:

***Thank you for purchasing a mortar mixer MIX 60 PLUS from an IMER U.S.A. dealer.  
Your decision is an intelligent one.  
No other mixer in the world today offers the features and value of the MIX 60 PLUS.***

- \* After the initial set-up the Mixer can be knocked down or reassembled in just minutes.
- \* Direct drive of the paddle, efficient and safe.
- \* Compact, the clever design allows the **MIX 60 PLUS** to fit into the trunk or hatchback area of almost all cars and trucks.
- \* Finish, the high quality of paint and construction components ensure a piece of equipment that you will be proud to own for years.

*At IMER U.S.A. we continually search for ways to better serve our customers. Should you have an idea or thought to share with us regarding this Product we would appreciate hearing from you. Our motto is **"Tools and Services for the 21st Century"**. We look forward to delivering the goods.*

*Thank you again for your purchase,*



*Mace T. Coleman, Jr.  
President, IMER U.S.A. Inc.*

*221 Westhampton Place  
Capitol Heights, MD 20743*

*Ph / 800.275.5463*

## **TABLE OF CONTENTS**

<b>TECHNICAL DATA .....</b>	<b>page 4</b>
<b>DESIGN STANDARDS .....</b>	<b>page 5</b>
<b>NOISE EMISSION LEVEL .....</b>	<b>page 5</b>
<b>OPERATION SAFETY .....</b>	<b>page 5</b>
<b>ELECTRICAL SAFETY .....</b>	<b>page 5</b>
<b>ASSEMBLY .....</b>	<b>page 5</b>
<b>TRANSPORT .....</b>	<b>page 5</b>
<b>INSTALLATION.....</b>	<b>page 5</b>
<b>ELECTRICAL CONNECTION.....</b>	<b>page 5</b>
<b>START-UP .....</b>	<b>page 5</b>
<b>OPERATION.....</b>	<b>page 5</b>
<b>APPLICATIONS .....</b>	<b>page 6</b>
<b>EMERGENCY STOP.....</b>	<b>page 6</b>
<b>CLEANING .....</b>	<b>page 6</b>
<b>MAINTENACE.....</b>	<b>page 6</b>
<b>TROUBLE-SHOOTING .....</b>	<b>page 6</b>
<b>WIRING DIAGRAM .....</b>	<b>page 7</b>
<b>SPARE PARTS .....</b>	<b>page 8</b>
<b>WARRANTY .....</b>	<b>page 10</b>

## TECHNICAL DATA

*Fig. 1*

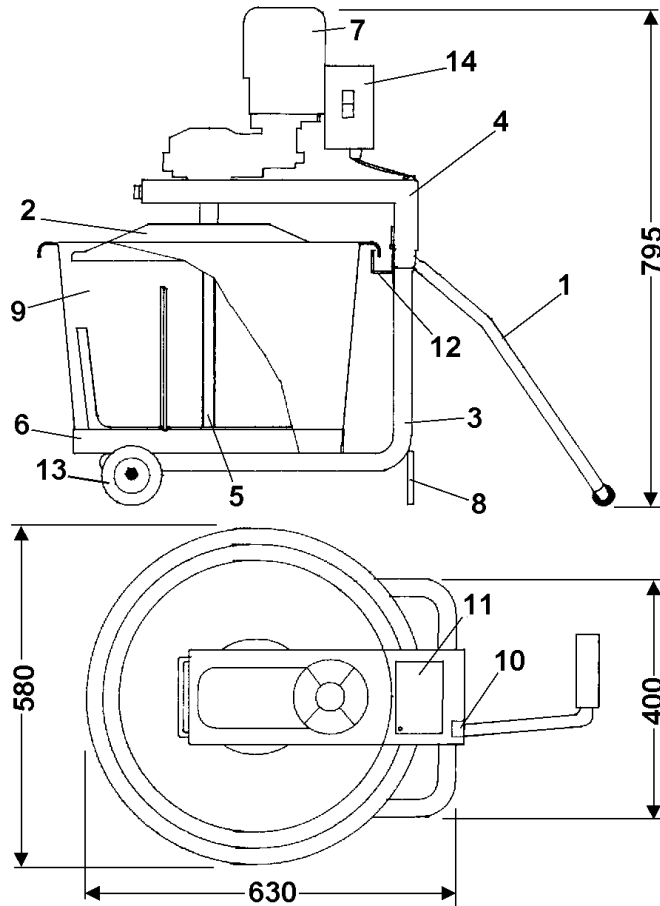

1	HANDLE
2	SAFETY GRID
3	FRAME
4	REDUCTION UNIT SUPPORT
5	BLADE ASSEMBLY
6	TANK HOUSING
7	GEARMOTOR
8	LEGS
9	TANK
10	LIMIT SWITCH
11	DATA PLATE
12	TANK BRACKET
13	WHEEL
14	ELECTRICAL PANEL

TECHNICAL SPECIFICATIONS		
Drum capacity	gal (liter)	15 (56)
Drum diameter	in (mm)	22.8" (580)
Paddle rpm	RPM	55
Machine weight	lbs (Kg)	67 (30)
Machine weight with packing	lbs (Kg)	71 (32)
Packing dimensions	in (mm)	24.4x23x17.9 (620x585x455)
)Wheel dimensions	in (mm)	Ø 3.9x0.8 (Ø100x20)
Motor rating	HP (Kw)	0.75 (0,55)
Paddle rotation direction		clockwise
Absorbed current	A	7
Voltage	Volt	115
Frequency	Hz	60

Dear Customer,

Congratulations on your choice of purchase: IMER mixers are universal machines for MIX series: the MIX series mixers are ideal for mixing dry or wet fine particle material (gypsum, cement, ceramic tile adhesives, plaster, epoxy resin or proprietary mixed products).

### **WORKING IN SAFETY**

**To work in complete safety, read the following instructions carefully.**

- This OPERATION AND MAINTENANCE manual must be kept on site by the person in charge, e.g. the SITE FOREMAN, and must always be available for consultation.
- The manual is to be considered integral part of the machine and must be kept for future reference until the machine is disposed of. If the manual is damaged or lost, a replacement may be requested from the saw manufacturer.
- The manual contains important information regarding site preparation, machine use, maintenance procedures, and requests for spare parts. Nevertheless, the installer and the operator must both have adequate experience and knowledge of the machine prior to use.
- To guarantee complete safety of the operator, safe operation and long life of equipment, follow the instructions in this manual carefully, and observe all safety standards currently in force for the prevention of accidents at work (use of safety footwear and gloves in accordance with S.I. N°3073 of 30/11/92).

Pay special attention to warnings bearing the following symbol:



**- MAKE SURE THAT SIGNS ARE LEGIBLE.**



**- It is strictly forbidden to carry out any form of modification to the steel structure or working parts of the machine.**

IMER INTERNATIONAL declines all responsibility for non-compliance with laws and standards governing the use of this equipment, in particular: improper use, defective power supply, lack of maintenance, unauthorised modifications, and partial or total failure to observe the instructions contained in this manual.

### **1. DESIGN STANDARDS**

The MIX 60 mixer has been designed and constructed in accordance with the following standards: I.E.C.34.4; EN 60204-1; EN 392 (91/368 CEE).

### **2. NOISE EMISSION LEVEL**

Operator exposure to sound emission levels: the MIX 60 PLUS mixer noise level during operation is measured at 65 dB(A).

### **3. OPERATION SAFETY**

- The Imer MIX 60 PLUS cement mixer may only be used when fitted with all required safety devices which must be in perfect working condition.
- Keep well clear of the mixing tank during operation.
- Never connect MIX 60 PLUS to defective power lines.
- Make electrical connections on the construction site where they will not be subject to damage.
- Lay power cables where they are not subject to risk of damage or penetration of water into connectors. Only use connectors electrically protected against water sprays.
- Never connect the mixer to makeshift mains connections. If necessary, consult qualified personnel.
- Repairs to electrical installations must only be carried out by qualified technicians. Do not operate the mixer during maintenance or repairs.
- Observe all accident prevention and safety standards in the work area.

### **4. ELECTRICAL SAFETY**

The IMER MIX 60 PLUS is designed in compliance with EN 60204-1 standards and features water spray protection (IP54) and overload protection.

The mixer is also fitted with a safety system comprising a limit switch which shuts off machine operation whenever the reduction unit support is lifted.

To reset, press the green pushbutton located in the electrical cabinet.

### **5. ASSEMBLY**

- Position the frame and handle as shown in fig.2.
- Insert the link pin and the cotter pin and tighten.
- Insert the tank in the circular housing, ensuring that the four handles fit onto the steel brackets. To prevent tank rotation during operation.
- Fit the safety grid, blade cover and screw the blade fully down (fig.3).

### **6. TRANSPORT**

 **- Warning: Always unplug the mixer from the power supply before handling.**

- MIX 60 PLUS is easily transported; use the handle indicated in fig.4 for manual transport of the mixer.



**- Never use the power cable to pull the machine.**



**- Never pull the power cable to unplug the machine.**

### **7. INSTALLATION**

- Remove the machine from the packaging.
- Install the mixer on level and solid ground



**- Do not tilt the mixer during operation.**

- When transporting the machine ensure that there are no obstacles which may impair stability.

### **8. ELECTRICAL CONNECTION**

**- Ensure that mains voltage and cable sizes correspond to specifications.**

- MIX 60 PLUS is fitted with an ac motor which must be connected to a 115 V power supply with a cable fitted with suitable wear-resistant, anti-crushing and weatherproof sheathing. Cable length must not exceed 50 yards.



**- MIX 60 PLUS must only be used when fitted with all required safety devices, which must be in perfect working condition.**



**- Lay power cables where they are not subject to risk of damage or penetration of water into the connectors.**



**- Only use connectors electrically protected against water sprays. Do not stand the machine on the power cable.**



**- Never use the mixer with a makeshift power connection.**



**- The electrical connection must be carried out by a qualified technician.**

- Ensure that the cable is securely clamped inside the plug and socket.



**- Observe all accident prevention and safety standards in the work area.**

- During mixer operation, do not insert tools or other objects in the tank to avoid damage to the mixer or operator safety hazard.

### **9. START-UP**

Press the green button to start the mixer.

If the mixer blades do not rotate the overload cutout switch trips to shut down the machine. Press "ON" to resume operation.

### **10. OPERATION**



**- Ensure that the power cable is fitted with a residual current circuit breaker upline of the machine.**

- Make sure that all other persons keep clear of the mixer during operation.

- Do not use the mixer in areas subject to the risk of fire.

- Switch the mixer off before leaving it unattended.

- Make sure that the mixer is completely immobile before handling or installation.

- Make sure that the mains voltage corresponds with the indications on the mixer data plate.



**- Make sure that the mixer blades rotate clockwise.**



**- Make sure that no clothing comes into contact with mixing blades.**



**- Warning: Never start the mixer without the safety grid fitted; the cover is a safety device and must be fitted to avoid direct contact with the mixer blades.**

**11. APPLICATIONS**

**11.1. ADHESIVES FOR CERAMIC TILES, FLOORING AND WALL CLADDING**

Pour in the quantity of water as required for the relative product, considering that the maximum mixer capacity 100 lbs of adhesive. Start the machine and during operation, pour the powder directly over the plastic cover to obtain a smooth mixture.

 - **Warning: when mixing large quantities, pour the product into the tank gradually.**

**11.1. PAINT**

Pour in the required amount of paint and water.

 - **The use of acid, solvents, and other aggressive chemical products is strictly prohibited.**

**11.1. CEMENT**

Mix 60 can also mix mortar, cement, or lime provided that a fine particle size is used.

 - **Warning: Avoid excessive stiffening of the mixture due to the addition of too much cement, lime or other water absorbing products.**

**12. EMERGENCY STOP**

 - **In an emergency, press the green pushbutton and unplug the mixer.**

 - **The electric motor is protected from thermal overload; if the motor overheats the mixer is shut down automatically. Allow the motor to cool before resuming operation.**

**13. CLEANING**

After each work shift and before prolonged periods of disuse, clean the tank interior and exterior thoroughly.

 - **Always unplug the mixer from the mains before cleaning (also when using brushes, cloths or scrapers etc.).**

 - **Never operate the mixer during cleaning operations.**  
- When using water jets for cleaning, never direct the water at the mixer drive unit.

**14. MAINTENANCE**

 - **Warning: Always switch off the mixer and unplug from the power supply before carrying out maintenance.**

- Repairs to the electrical installation must be carried out exclusively by qualified personnel. Replacement parts must be original IMER spare parts and must not be modified in any way.

The IMER MIX 60 PLUS is designed for minimum maintenance requirements. However, we recommend changing the reduction unit oil after 3000 hours continuous duty with SAE 40 oil.

Check that the socket/plug contacts are clean. If oxidised, clean immediately.

 - **Used oil is considered a special waste product and must be disposed of in accordance with the law.**

 - **Always ensure that signs and warning notices on the machine are clearly legible.**

For any problem, see your dealer or call IMER U.S.A. @ 800.275.5463.

**15. TROUBLE-SHOOTING**

PROBLEM	CAUSE	REMEDY
The motor does not start when switched on	No power on power cable	Check power cables
	Plug not inserted correctly in socket	Ensure correct connection
	Faulty power cable to electrical panel	Change power cable
	Loose wire in electrical panel	Reconnect wire
	Loose wire in motor terminal board	Reconnect wire
	Faulty main switch	Replace switch
The motor does not stop when the safety grid is lifted	Residual current circuit breaker tripped	Reset switch. If it does not reset, refer to a qualified electrician to check the electrical system to ensure complete safety.
	Faulty limit switch	Replace limit switch
Motor starts with difficulty	Mixture is too stiff	Reduce mixture quantity or dilute and try again.
Should the problem persist	Contact IMER Technical Service @ 800.275.5463 or your IMER Dealer	

**WIRING DIAGRAM**

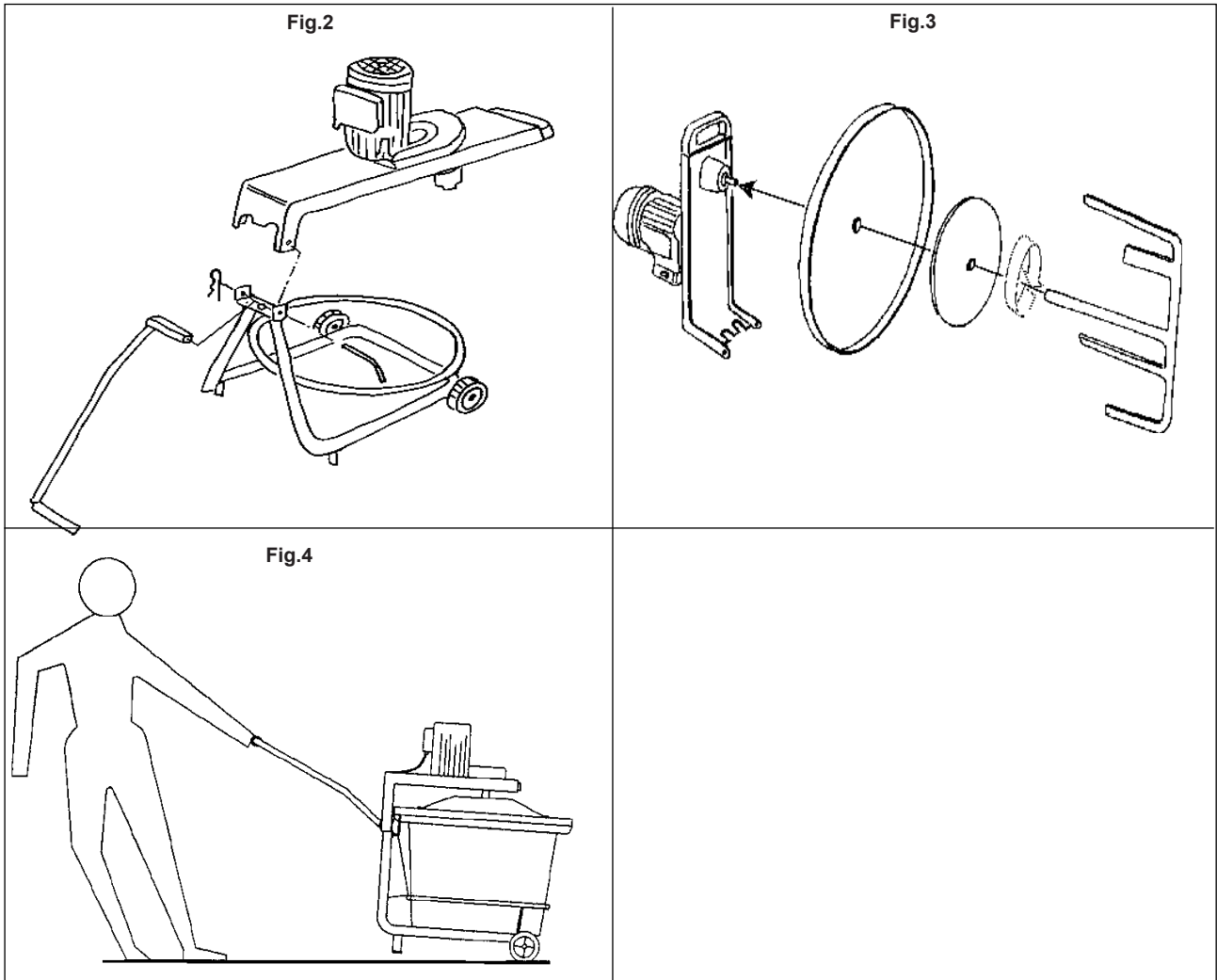
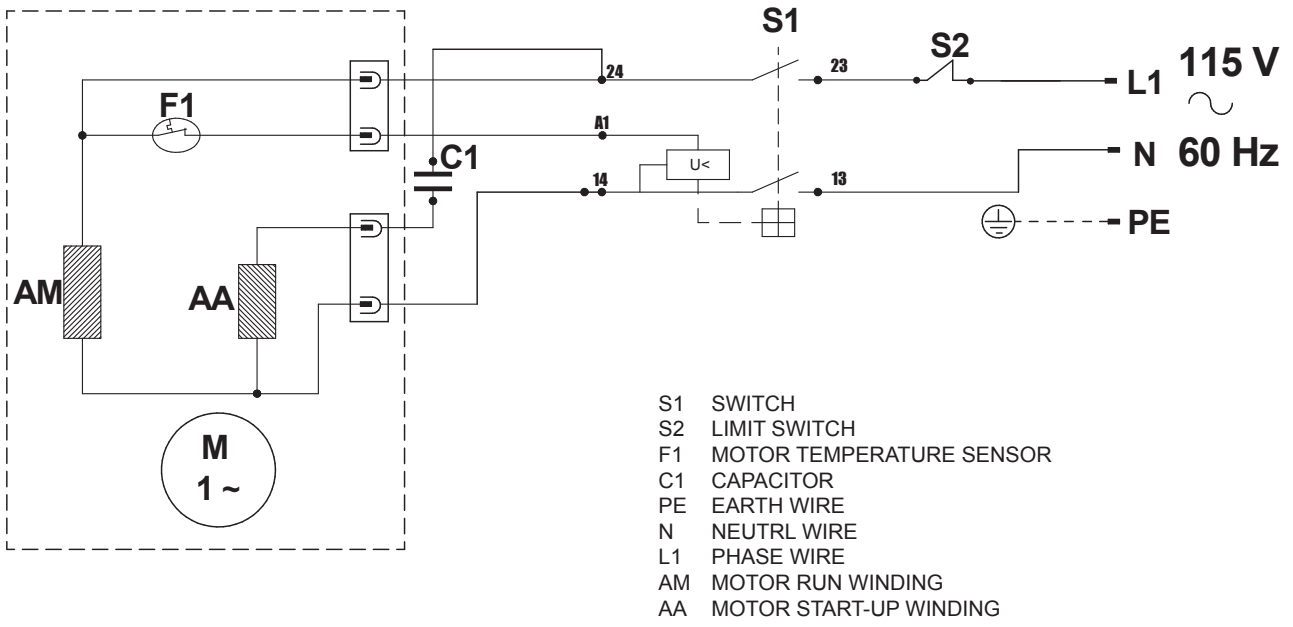

## SPARE PARTS

All orders for spare parts must include the following:

- 1) Type of machine. (Example: MIX 60 PLUS mixer)
- 2) Part number and drawing references of each part, see the parts list.
- 3) Serial number and year of manufacture recorded on the machine's identification plate.

DIAGRAM #1 GEARMOTOR ASSEMBLY COD. 3233150			
RIF.	P.n.	Description	Note
1	3233104	GEARBOX CASE-HALF	
2	2204420	BEARING	6201
3	3233054	PINION GEAR	
4	3233061	GEAR	
5	2204550	BEARING	6205
6	3233056	MAIN SHAFT	
7	3233053	GEAR	
8	2204504	BEARING	6008
9	2207405	OIL SEAL	55X40X10
10	3230256	GEARBOX GASKET	
11	3210485	GEARBOX CASE-HALF	
12	3210955	PLUG WITH CABLE	
13	2229500	KEY	8X7X15
14	2229249	KEY	5X5X12
15	2228819	PIN	Ø6X12
16	2222012	BOLT	M6X60
17	2222010	BOLT	M6X25
18	2224530	WASHER	Ø6
19	2223260	NUT	M6
20	3209214	GASKET	
21	3200005	LIMIT SWITCH	
22	3210904	FAN	
23	3233097	FAN COVER	
24	3210233	SWITCH	
25	3233059	OIL SEAL	15x32x7
26	3208982	BEARING	6202
27	3210923	CAPACITOR	MF. 50 250V
28	3233156	ELECTRIC PANEL	
29	3233056	ELECTRICAL BOX	
30	3233155	MOTOR+GEARBOX CASE-HALF	115V/60Hz
31	3209340	PROTECTION COVER	

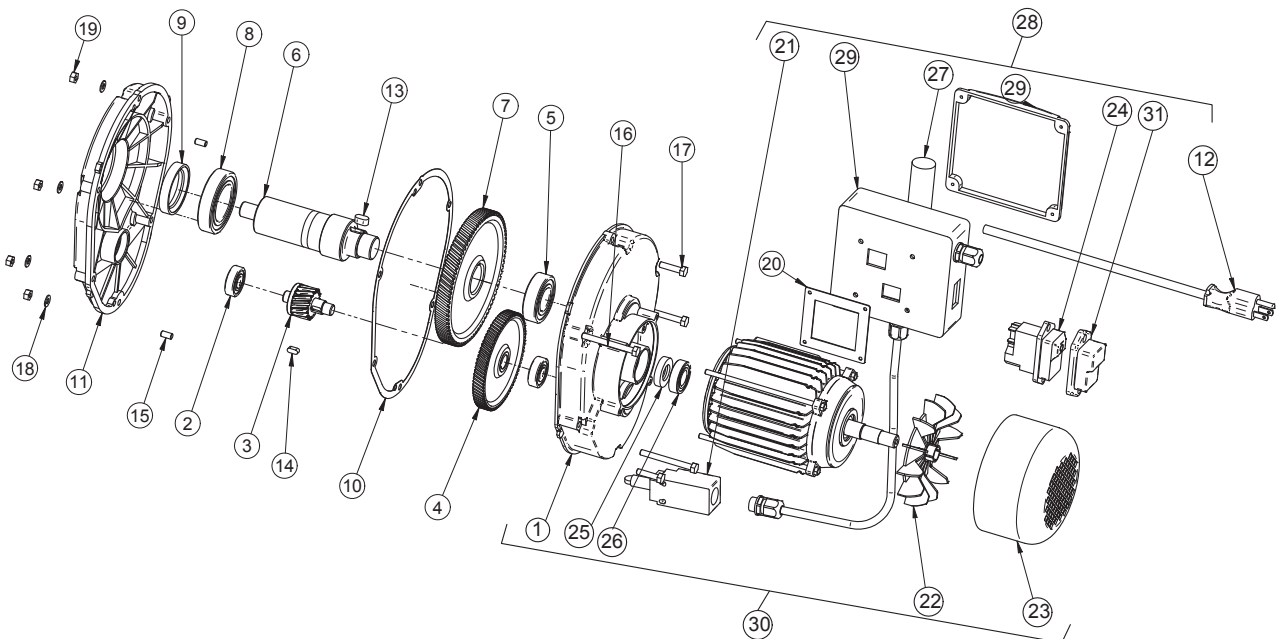
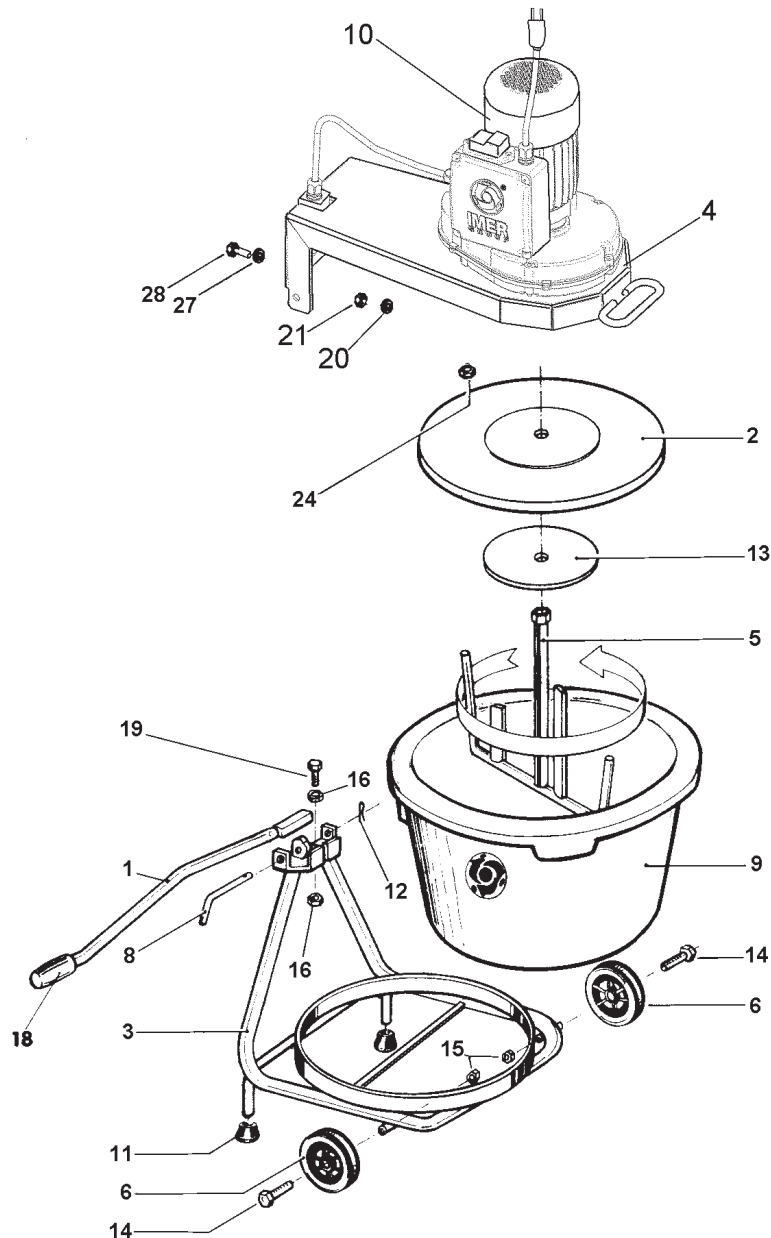



DIAGRAM #2 MORTAR MIXER			
RIF.	P.n.	Description	Note
1	3205592	HANDLE	
2	3205607	COVER	
3	3206584	FRAME	
4	3233048	SUPPORT	
5	3205587	COMPLETE PADDLE	
6	3205257	WHEEL	
8	3205623	PIN	
9	3210432	TANK	
10	3233150	GEARMOTOR	
11	3205926	PLUG	
12	2226703	SPLIT PIN	
13	3205611	STEEL DISK	
14	2222154	BOLT	M10X120
15	2223920	SELF LOCKING NUT	M10
16	2223705	NUT	M12
18	3206079	HANDLE	
19	2222083	BOLT	M12X70Z
20	2224950	WASHER	Ø4
21	2223500	NUT	M4
24	2223924	NUT	A 6
27	2224535	WASHER	
28	3204186	SCREW	M4X40





## **EQUIPMENT WARRANTY**

### **IMER U.S.A. INC.**

#### **HEADQUARTERS**

*221 Westhampton Place  
Capitol Heights, MD  
20743  
Ph / 800.275.5463*

We warrant to the original purchaser that the IMER equipment described herein (the "equipment") shall be free from defects in material and workmanship under normal use and service for which it was intended for period of one (1) year from the date of purchase by the original purchaser.

Our obligation under this warranty is expressly limited to replacing or repairing, free of charge, F. O.B. our designated service facility, such part of the equipment as our inspection shall disclose to be defective. Parts such as engines, motors, pumps, valves, electric motors, etc. furnished by us, but not manufactured by us, will carry only the warranty of the manufacturer. Transportation charges or duties shall be borne by purchaser. This shall be the limit of our liability with respect to the quality of the equipment.

This warranty shall not apply to any equipment, or parts thereof, which has been damaged by reason of accident, negligence, unreasonable use, faulty repairs, or which has not been maintained and operated in accordance with our printed instructions for the equipment. Further, this warranty is void if the equipment, or any of its components, is altered or modified in any way.

**THIS WARRANTY IS EXPRESSLY IN LIEU OF ALL OTHER WARRANTIES, EXPRESSED OR IMPLIED, INCLUDING ANY IMPLIED WARRANTY OF MERCHANTABILITY OR FITNESS FOR A PARTICULAR PURPOSE.**

We make no other warranty, representation or guarantee, nor is anyone authorized to make one on our behalf. We shall not be liable for consequential damage of any kind, including loss or damage resulting, directly or indirectly, from the use or loss of use of the machine. Without limiting the generality of the foregoing, this exclusion from liability embraces the purchaser's expenses for downtime, damages for which the purchaser may be liable to other person, damages to property, and injury or death of any persons.

This warranty shall not be deemed to cover maintenance parts, including but not limited to blades, belts, hoses, hydraulic oil, or filters, for which we shall have no responsibility or liability whatsoever.