

ORUREADY XS

MOBILE DRY BATCHING SYSTEM



ORUREADY

EASY TO TRANSPORT AND EXTREMELY MOBILE

ORUREADY XS is a mobile dry batching system that can be easily transported and ready to use.

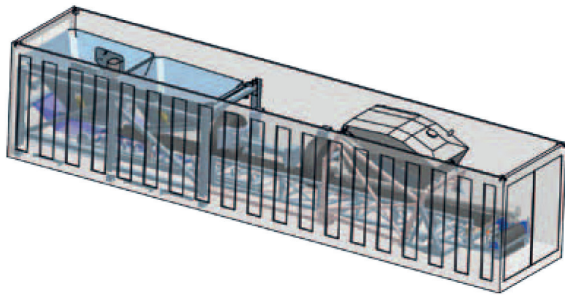

COMPACT: EVERYTHING IN ONE CONTAINER

The **ORUREADY XS** mobile system is designed to be compact and fit into one shipping container for minimal transport costs and ready to use.



VERSATILE

The **ORUREADY XS** is engineered to include a wheelbase allowing the unit to be easily towed while fully assembled. In addition, the XS is completely pre-wired and equipped with a control panel making it ready to use upon delivery.

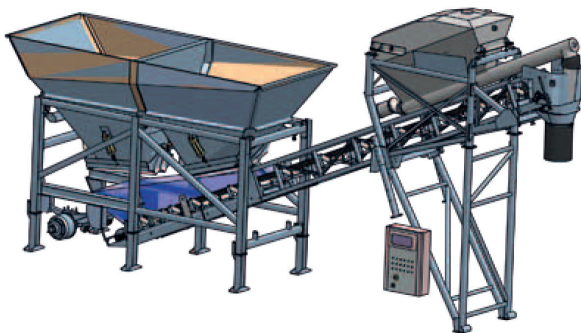

FAST AND EASY

No additional work is required to install the **XS** on site. Compacted soil or crushed stone is all that is required to allow delivery trucks to the work site.

ORUREADY XS DRY SYSTEM: COMPLETELY MOBILE. EASY TO TRANSPORT. READY TO USE.

ORUREADY XS with maximum hourly production of 157 yd³/h (120 m³/h) and 31-½ inches (800 mm) picking belt. The production capacity refers to a typical composition per cubic yard or meter of vibrated concrete.

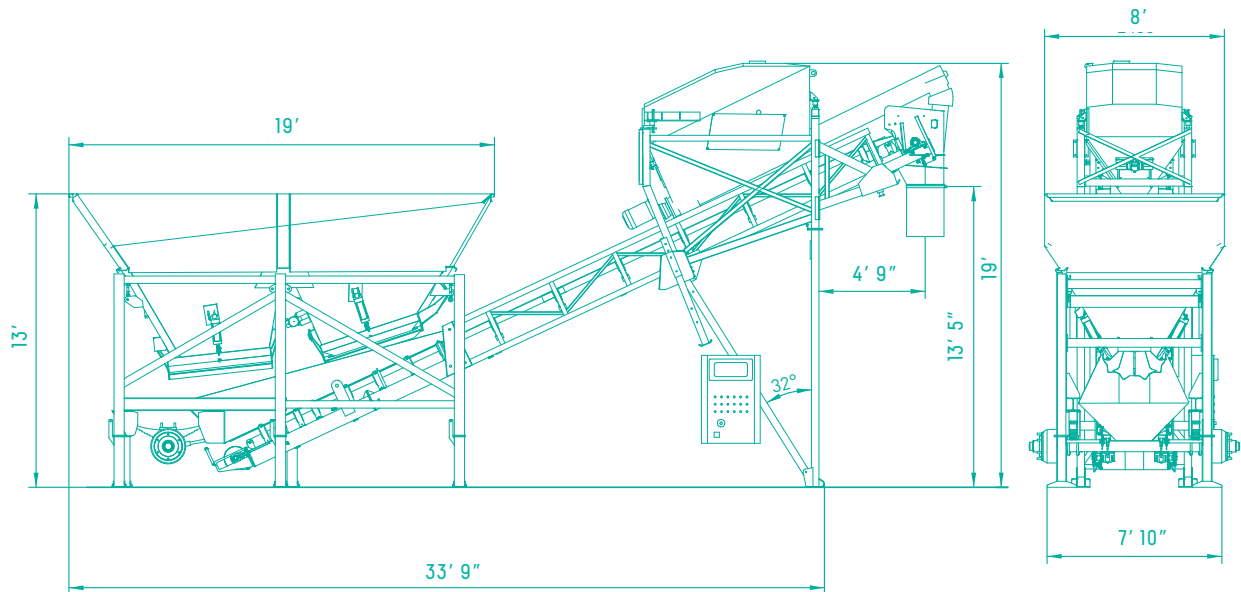

VERY COMPACT

The compact height makes it easier to load materials, and the compact length allows the unit to transport easily.

FULLY PRE-WIRED

ORUREADY XS is completely pre-wired to the power panel assembled on the machine. The system is equipped with a control unit for the preparation of multi-formula recipes with automatic management.

The panel is pre-set for the management of two worm screws, two fluidifying devices to introduce air into the silo to avoid clumping, two de-dusting filters, and setup for two additives.

RESISTANCE AND LONG SERVICE LIFE

The load-bearing structures are sturdy (calculated for seismic class C12 and wind speeds of up to 75mph / 120 km/h). They are heat galvanized to ensure the most extended service life and corrosion resistance.

DATA SHEET



AGGREGATE HOPPERS

Galvanized	2X			
Hopper 1 (rear) storage capacity	m ³	8.5	yd ³	11.2
Hopper 2 (front) storage capacity	m ³	7.4	yd ³	9.6

Homologated weighing system with traction cells

EXTRACTOR BELT

Complete with conveyer funnel and rubber boot for truck mixer

Length	m	10.2	ft	33.5
Width	cm	80	in	30
Capacity	m ³	260	yd ³	340
Power	kW	15	hp	20

CEMENT WEIGHING HOPPER

Weighing hopper capacity	m ³	2.8	yd ³	3.7
4X traction weighing cells for hopper - capacity	kg	3,000	lb	6,615
Screw feeder - diameter	mm	323	in	12.7
Screw feeder - power	kW	9.2	hp	12

WATER SYSTEM

Pulse meter dn50

2" pneumatic butterfly valve

PNEUMATIC SYSTEM

Compressor	NI/min	486	cfm	17
Power	kW	3	hp	4
Tank capacity	l	270	gal	71

OPTIONS

Cement silo and screw feeder

Fluidifier accessories

Water pump 238 gal/m (900 l/min), power 10 hp (7,5 kw)

Silo safety system (kcs)

Management unit hps 2100v (computer)



TOLL FREE: 800.275.5463
WWW.IMERUSA.COM



TOGETHER WE BUILD

IMER USA, Inc.
423 Bank Street, Suite 180
Southlake, TX 76092
Tel. (800) 275-5463 - Fax (301) 336-6687
www.imerusa.com



IMER Group | USA (IMER USA, Inc.) reserves the right to change the information contained herein without prior notice when considered justified. The data and dimensions are not to be considered as binding. The illustrations may include accessories and could be slightly different from the standard versions of the equipment.

© Copyright by IMER Group | USA